



昇洋機械股份有限公司 SHENG YANG MACHINERY CO., LTD.

SHENG YANG

押出機專業設計 · 研發 · 製造廠

Plastic Extruder Professional Design, R&D, Manufacturer



專業的技术 用心的服务 Professional Technology, Heart Services





公司簡介 COMPANY PROFILE



昇洋機械是由一群押出機設計製造及銷售的專業人才所組合而成。本著豐富的經驗及優異的專業技術，致力於先進單螺桿及積木式同向雙螺桿押出機的研究設計開發製造。從生產的品質管制到實機的測試運轉，皆經嚴格控管，以確保機器之高質量、高精密度、高附加價值的需求，讓專業的技術落實於產品的製造與應用之上。

本公司不斷接受客戶新材料與機器的委託設計開發製造，獲得國內外客戶高度的肯定與評價。高品質、高產能、高效率及降低成本的設計理念，正是獲得客戶高度青睞的主要原因。

有感於塑膠化工材料之日新月異，昇洋將不斷的投入創新研發新的機器以滿足客戶之需求。以更虛心、創新、責任、精益求精之態度，繼續努力向前邁進。

企業宗旨：『專業的技術、用心的服務』、以客為尊、誠懇穩健、永續經營。

SHENG YANG Machinery is a group of design and manufacture of extrusion machines and the sale of a combination of professionals. Based on their extensive experience and superior technical expertise, commitment to advanced and modular single-screw and segmented co-rotating twin-screw extruder with the research design and development of manufacturing. Quality control from production to the real machine test run, are under strict control to ensure high-quality machines, high precision, high value-added demand for professional technical implementation of the manufacture and application of the product above.

The company continued to accept clients commissioned new materials and machinery design and development of manufacturing, access to domestic and international clients a high degree of recognition and evaluation. High-quality, high performance, high efficiency and reduce costs of the design concept, it is the main reason to obtain highly favored customers.

Responding to the ever-changing plastic chemical materials or foreign investment in innovation will continue to develop new machines to meet customer demand. A more open-minded, innovation, responsibility, excellence, attitude, continue to move forward.

Corporate purposes : 『**professional technology, heart services**』 customer-oriented, honest sound, sustainable business.

REX系列積木式同向雙螺桿押出機

REX series segmented co-rotating twin screw extruder



水中造粒 Underwater Pelletizer

型式(Model No.): SY-REX20、32、43、58、72、77、92、112

Screw diameter:

20mm、32mm、43mm、58mm、72mm、77mm、92mm、112mm

適用原料(Applications):

PP、EVA、SBS、SEBS、TPR、TPE、TPV、TPO、TPU



PLC人機界面電腦觸控銀幕

PLC man-machine interface with touch screen computers





REX系列積木式同向雙螺桿押出機

REX series segmented co-rotating twin screw extruder

拉條造粒 Strand Pelletizer

型式(Model No.): SY-REX20、32、43、58、72、77、92、112

Screw diameter: 20mm、32mm、43mm、58mm、72mm、77mm、92mm、112mm

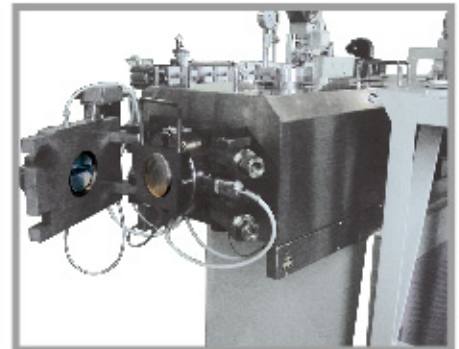

適用原料(Applications):

PP、PE、PS、PC、PET、PBT、POM、PMMA、PA、

PPE(PPO)、ABS、AS、PC/ABS、TPR、TPE

PP、PA、PC、PBT、ABS + GF

PP + CaCO₃、PP + TALC、PP + TiO₂

REX系列積木式同向雙螺桿押出機

REX series segmented co-rotating twin screw extruder

拉條造粒 Strand Pelletizer

型式(Model No.): SY-REX20、32、43、58、72、77、92、112

Screw diameter: 20mm、32mm、43mm、58mm、72mm、77mm、92mm、112mm



適用原料(Applications):

PP、PE、PS、PC、PET、PBT、POM、PMMA、PA、
PPE(PPO)、ABS、AS、PC/ABS、TPR、TPE

PP、PA、PC、PBT、ABS + GF

PP + CaCO₃、PP + TALC、PP + TiO₂



REX系列積木式同向雙螺桿押出機

REX series segmented co-rotating twin screw extruder

失重式自動計量系統

LOSS-IN-WEIGHT FEEDING SYSTEM

型式(Model No.): SY-ASF - Single screw · SY-ATF - Twin screw

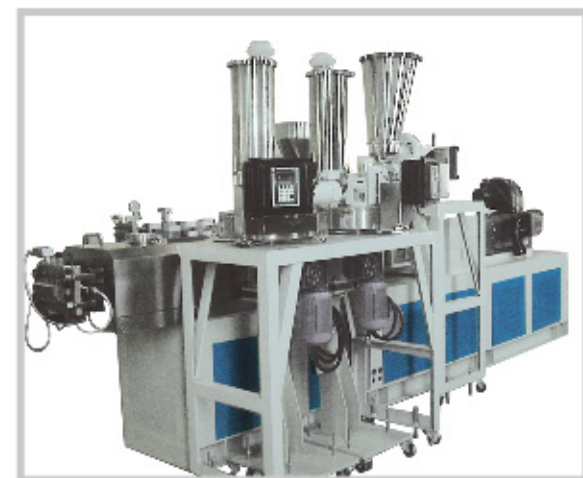

連續性、高效率、準確性的生產線是目前企業追求的目標。自動計量系統可對原材料之配比進行連續精確的計量，以達高精度、高品質之目的。且可避免人工配料所出現之失誤。

Continuity, efficiency, accuracy of the production line is the pursuit objectives of enterprise. Automatic measurement system can process the continuous precise measurement of the ratio of the raw material, to achieve high precision, high-quality purposes. And can avoid the mistakes of artificial ingredients are there.



REX系列積木式同向雙螺桿押出機

REX series segmented co-rotating twin screw extruder

水環造粒機

Water ring pelletizer

型式(Model No.): SY-REXC20、32、43、58、72、77、92、112

Screw diameter: 20 mm、32mm、43mm、58mm、72mm、77mm、92mm、112mm



設備優點：

低噪音、高產量、扁形粒子可調整大小、設備空間較小、效率高。

適用材質：

各種的聚合物及複合材料，如LDPE、LLDPE、HDPE、PS、ABS、TPR、PP+CACO3、PE black master batch等。

Equipment advantages:

Low noise, high output, flat particle resizable, equipment less space, and high efficiency.

Application:

All kinds of polymers and composites, such as LDPE、LLDPE、HDPE、PS、ABS、TPR、PP + CACO3、PE black master batch, etc.



REX系列積木式同向雙螺桿押出機

REX series segmented co-rotating twin screw extruder

型式(Model No.): SY-REX20、32、43、58、72、77、92、112

Screw diameter: 20mm、32mm、43mm、58mm、72mm、77mm、92mm、112mm

應用領域：

功能性母粒、高濃縮色母、
黑白色母、填充改性、共混
改性、玻纖及碳纖增強、
反應押出、聚合、均質化。

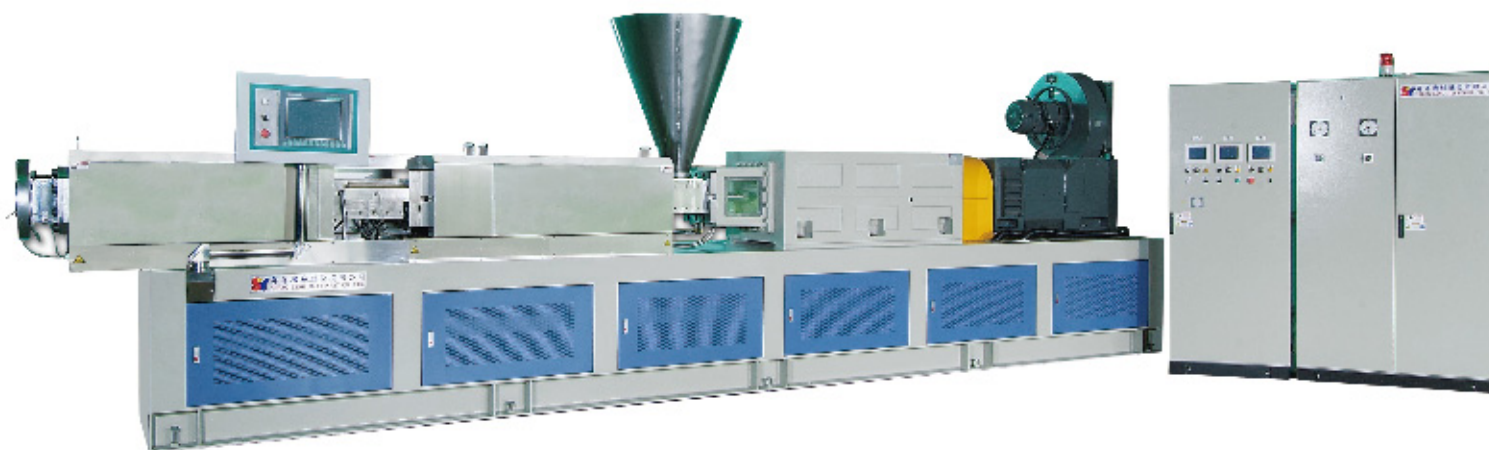

Applications:

Functional master batch、high concentrate
master batch、white & black master batch、
filling & modified、blending & modified、glass
fiber & carbon fiber reinforcement、reactive
extrusion、polymerization、homogenization。



側邊供料機 Side feeder
Model No. : SY-TFD
Screw diameter :
35mm、50mm、63mm



主喂料機 Main feeder
Model No. : SY-TSF
Capacity from : 50-850Kg/hr

REX系列積木式同向雙螺桿押出機

REX series segmented co-rotating twin screw extruder

雙螺桿押出機設計特點：

- 1.螺桿：主機螺桿同向運轉，利用積木式之原理設計，具有良好之分散與混煉效果；同時可控制原料滯留料管之時間。更可依據不同配方做不同的排列組合，充分掌握了多功能、多用途、專用性等特徵。
- 2.組塊：具有良好之嚙合、互換、自清功能
- 3.料管：分為密閉、排氣、真空脫氣、側進料、液體注入孔、水噴霧孔。
- 4.傳動系統：
 - A. 齒輪箱：採用本公司自己設計之高精度、高轉速、高扭力齒輪箱。採用強制潤滑冷卻方式來潤滑冷卻齒輪及軸承。在高速運轉時平穩不震動，而且無噪音，齒輪及軸承壽命更長。
 - B. 扭力限制器：高速運轉時，可保護齒輪箱與螺桿，不會因突發意外而損壞。
5. 採用PLC人機界面電腦觸控銀幕。
6. 使用高效率AC馬達 + 變頻器。

Twin screw extruder design features:

1. Screw: Both screw running at the same direction, using the principle of building-block design, with good dispersion and mixing effects; also can control the raw material retention time inside the barrel. It can be different according to different combinations of arrangement. Take full advantage of the multi-function, multi-purpose, specific and other features.
2. Screw element: Excellent closely intermeshed, interchangeable, self-cleaning function.
3. Barrel (Block): Divided into closed, vent degassing, vacuum degassing, side feeder, liquid injected hole, water spray hole.
4. Transmission system:
 - A. Gear Box: using our own design of high precision, high speed, and high torque gear box. Gear Box adapts cooling method of enforced lubrication to cool gear and bearing lubrication. Smooth running at high speed without vibration, and no noise, longer gear and bearing life.
 - B. Torque limiter: high-speed operation, it can protect the gear box and the screw will not damage due to sudden and unexpected when high-speed operation.
5. PLC man-machine interface with touch screen computers.
6. Adapt high efficiency AC motor + inverter.





REX系列積木式同向雙螺桿押出機

REX series segmented co-rotating twin screw extruder

YouTube
Broadcast Yourself™



實驗室專用押出機

Laboratory Extruder

拉條造粒 Strand Pelletizer

型式(Model No.): SY-REX20

Screw diameter: 20mm



特性：

1. 本機器押出量少，試機時用料不多，可節省許多試料成本。
2. 切粒方式可依據客戶之需求。本機器可配合使用拉條造粒、模頭切粒、水環切粒、水中造粒。
3. 可依製程之需求採用自動計量系統、液體注入計量系統、側邊進料系統。
4. 本機器是化工、製藥、塑膠等產業開發新產品之最佳實驗機。

應用領域：

功能性母粒、高濃縮色母、黑白色母、填充改性、共混改性、玻纖及碳纖增強、反應押出、聚合、均質化。

REX系列積木式同向雙螺桿押出機

REX series segmented co-rotating twin screw extruder

實驗室專用押出機

Laboratory Extruder

水中造粒 Underwater Pelletizer

型式(Model No.): SY-REX20

Screw diameter: 20mm



Features:

1. Output of this machine is not many and the machine testing materials is not much, therefore it can save the cost of the testing materials.
2. Pelletizing way based on customer demand. The machine can be used in conjunction with strand pelletizer 、 die head cutting 、 water ring pelletizer 、 underwater pelletizer .
3. On processing demand, it can be used in conjunction with loss-in-weight system, liquid injected metering pump system, side feeder system.
4. This machine is the best laboratory extruder for using in chemical, pharmaceutical, plastics and other industries to develop new products.

Applications:

Functional master batch 、 high concentrate master batch 、 white & black master batch 、 filling & modified 、 blending & modified 、 glass fiber & carbon fiber reinforcement 、 reactive extrusion 、 polymerization 、 homogenization 。

REX系列積木式同向雙螺桿押出機

REX series segmented co-rotating twin screw extruder

水中造粒 Underwater Pelletizer

特性：

本機乃新型研發之創新設計，主要是針對需要生產完美球型粒子之生產廠家而設計。除可搭配單、雙螺桿押出機之外，亦可搭配熔融反應桶槽直接做造粒之動作。



適用材料：

EVA、TPU、TPR、TPV、TPO、TPE、SEBS、SBS、PP

產能：

200kg/hr~1500kg/hr

REX系列積木式同向雙螺桿押出機

REX series segmented co-rotating twin screw extruder

水中造粒 Underwater Pelletizer

Features:

This machine is the innovative design of new research and development, mainly design for the manufacturers whom need to produce perfectly spherical pellets. In addition can be used with a single, twin-screw extruder together, can be done directly with the melting reaction vessel for making pellets.

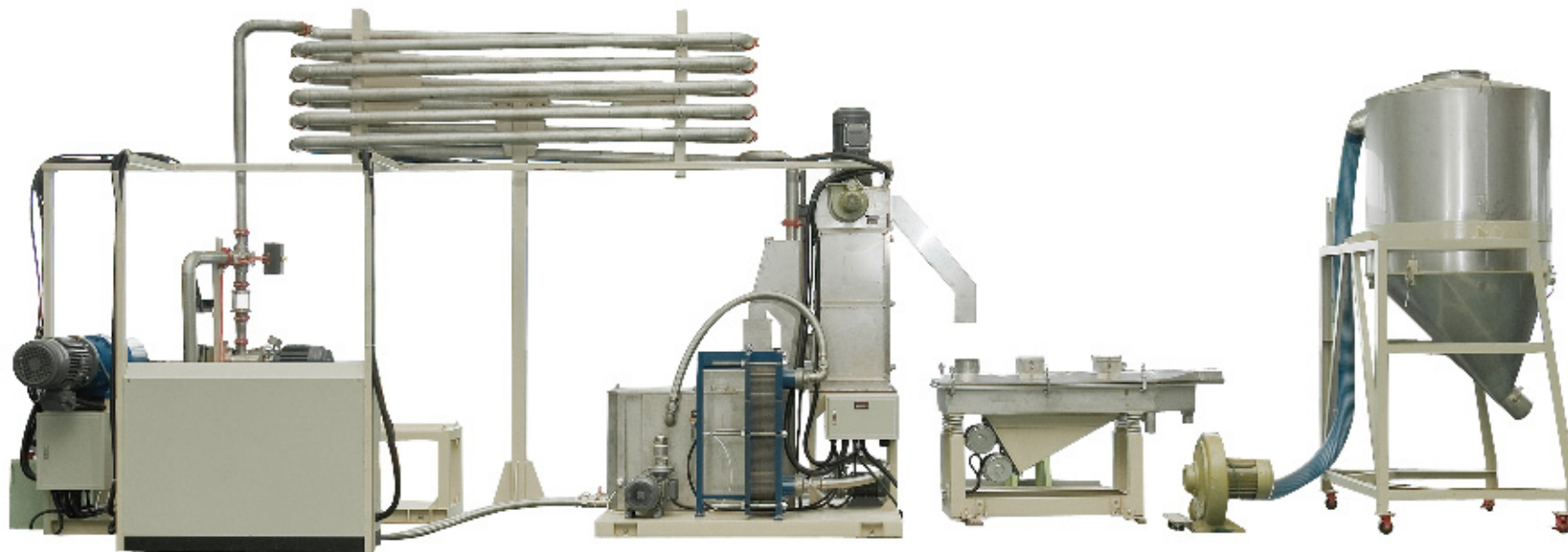

Application materials:

EVA, TPU, TPR, TPV, TPO, TPE, SEBS, SBS, PP

Capacity:

200kg / hr ~ 1500kg / hr



REX系列積木式同向雙螺桿押出機

REX series segmented co-rotating twin screw extruder

REX series segmented co-rotating twin screw extruder



組塊 Screw element



料管 Barrel



心軸 Shaft & 組塊 Screw element



可掀式料管、心軸、組塊
Opened-type barrel, Shaft, Screw element

REX系列積木式同向雙螺桿押出機

REX series segmented co-rotating twin screw extruder

REX系列積木式同向雙螺桿規格表 Technical data of REX series segmented Co-Rotating twin screw extruder

型號 Model	螺桿直徑 Screw Dia.	螺桿溝深 Channel depth	長徑比 L/D	Torque 扭力 N-M/Screw	螺桿轉速 Screw speed	驅動馬力 Driving Motor
SY-REX20	20 mm	3.4 mm	32-40	59 / Per shaft	600 rpm	7.5 HP
SY-REX32	32 mm	5.8 mm	32-40	110 / Per shaft	600 rpm	30 HP
SY-REX43	43 mm	7.4 mm	32-48	544 / Per shaft	600 rpm	75 HP
SY-REX58	58 mm	10 mm	32-48	1425 / Per shaft	600 rpm	175 HP
SY-REX72	72 mm	13.5 mm	32-48	2672 / Per shaft	600 rpm	300 HP
SY-REX92	92 mm	16.5 mm	32-48	5443 / Per shaft	600 rpm	500-700 HP
SY-REX112	112 mm	22 mm	32-48	9110 / Per shaft	600 rpm	600-1000 HP

REX系列積木同向雙螺桿押出機產能參考表

Reference output (KGS. / Per Hour) of REX series segmented twin screw compounding extruder

螺桿直徑 Screw Diameter	20 mm	32 mm	43 mm	58 mm	72 mm	77 mm	92mm	112 mm
黑白色母 White& black Pigments PP、PE、PS、PA、PET、ABS、AS	8-35	15-60	60-180	150-350	300-700	350-800	600-1200	850-1700
有機色母 Organic master batch ABS, AS, PS, PP, PE, PC, PET, PBT, EVA	6-18	10-30	60-100	200-300	250-350	300-400	600-800	850-1700
無機色母 Inorganic master batch ABS, AS, PS, PP, PE, PC, PET, PBT, EVA	12-30	20-50	110-150	250-350	400-600	450-850	900-1200	1600-2200
填充改性 Filling & modified PP, PE, EVA+caco3, Tio2, Talc PP, PA, ABS + Fee, Ceramic powder	12-30	20-50	120-220	400-700	800-1200	900-1300	1400-1800	2000-250
增強 Reinforced GF & carbon fiber PP, PA, PC, PBT, PET, POM, ABS, AS	12-25	20-40	90-180	280-450	500-700	550-750	700-950	1200-1700
反應押出 Reaction extruding TPU, organic matter reaction	6-18	10-30	60-100	100-150	250-350	300-400	500-700	700-900
塑膠合金 Polymers Alloy PC/ABS, PC/PBT, PBT/PET, PP/PE	8-25	15-40	100-150	300-400	500-700	550-750	700-950	1200-1700
熱可塑彈性體 Thermoplastic Elastomers SBS, SEBS, TPR, TPE, TPV, TPO	8-30	15-50	60-200	130-400	400-800	450-850	700-1300	1500-2350



REX系列積木式同向雙螺桿押出機

REX series segmented co-rotating twin screw extruder

粉末塗料 Powder coatings

型式(Model No.): SY-REXC50、65、80
Screw diameter: 50 mm、65mm、80mm

特性：

高扭矩、高轉速、高剪切。
混煉效果特佳。
料管掀開式設計，清料更容易。
螺桿本身具有自清功能。

應用範圍：

熱硬化塑料、聚氨酯類、聚酯類、
丙烯酸酯類、酯類、環氧類。

Features:

High torque, high speed, high shear.
Mixing efficiency is very high.
Opened-type barrel design, it is easy to clean
the material.
Screw itself has self-cleaning function.

Applications:

Thermosetting plastics, polyurethane, polyester,
acrylic, ester, epoxy.

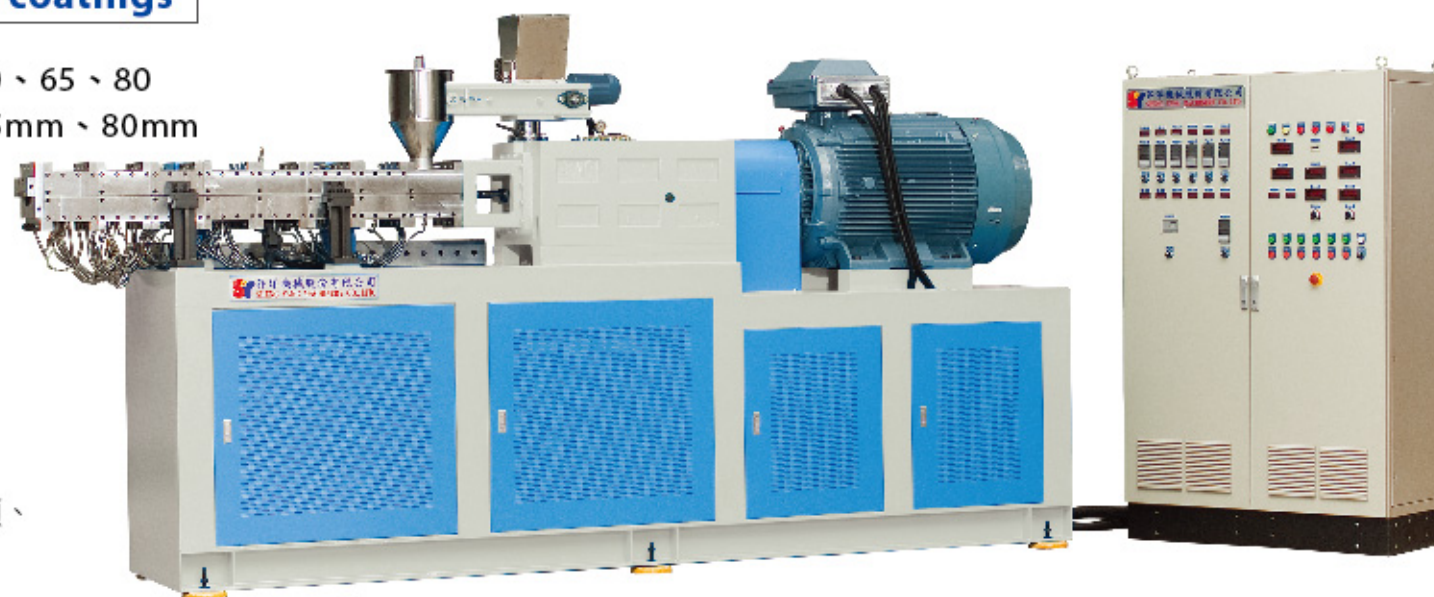

掀開式料管
Opened-type barrel

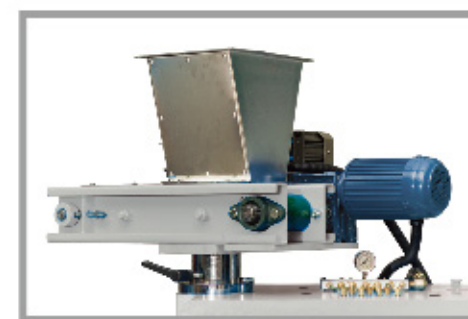

原料輸送機
Conveyor of raw material



REX系列積木式同向雙螺桿押出機

REX series segmented co-rotating twin screw extruder

食品級

Food grade

型式(Model No.): SY-REXF43、58、72、85、92

Screw diameter: 43 mm、58 mm、72mm、85mm、92mm



魚飼料

Fish feed for abalone

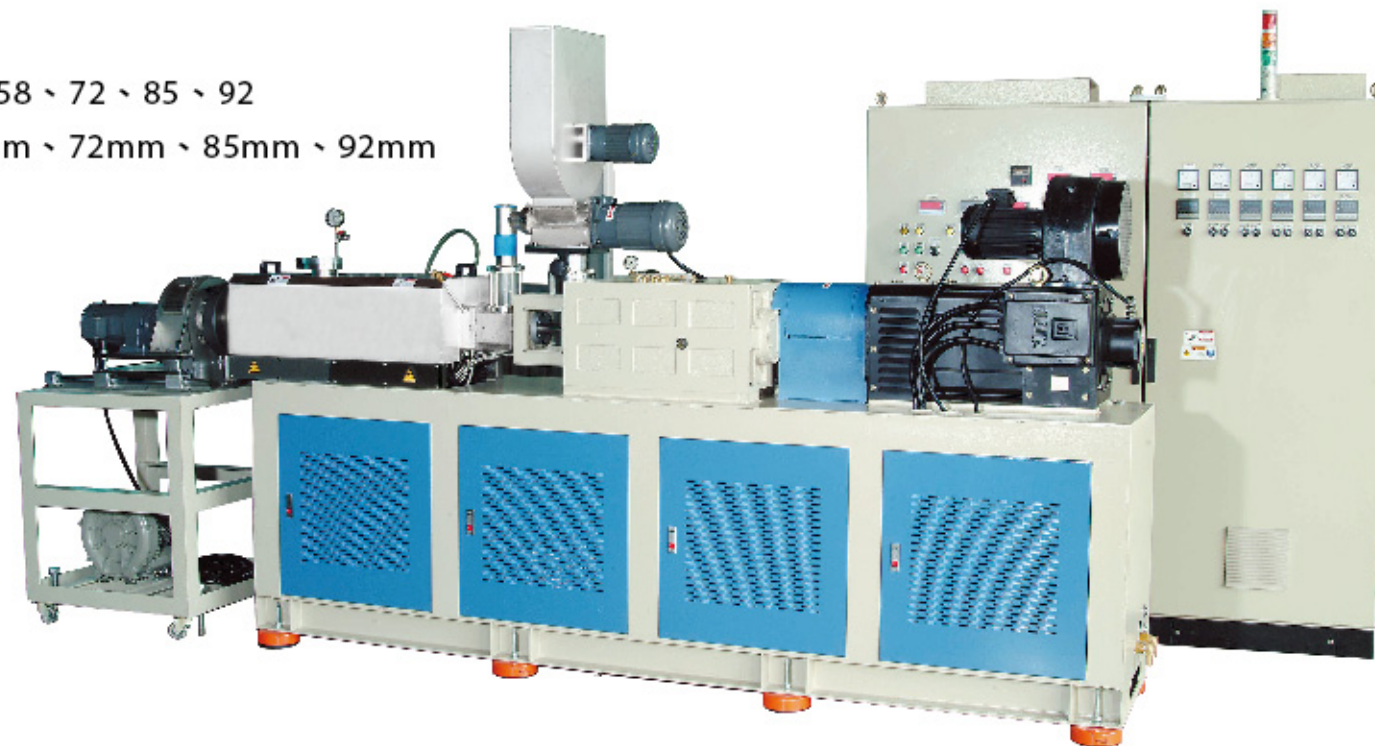

特性：

高扭矩、高轉速、高剪切。
螺桿與料管耐腐蝕性良好。
螺桿本身具有自清功能。

應用範圍：

養殖業飼料、膨化食品、組織性蛋白、植物蛋白。

Features:

High torque, high speed, high shear.
Screw and barrel well corrosion resistance.
Screw itself has self-cleaning function.

Application:

Aquaculture feed, puffed food, organizing protein, plant protein.



REX系列積木式同向雙螺桿押出機

REX series segmented co-rotating twin screw extruder

流程圖 Flowing chat

有機與無機填充、防火阻燃、合金混煉製程

Processing of organic filler & mineral filler、flame retardant、alloy compound

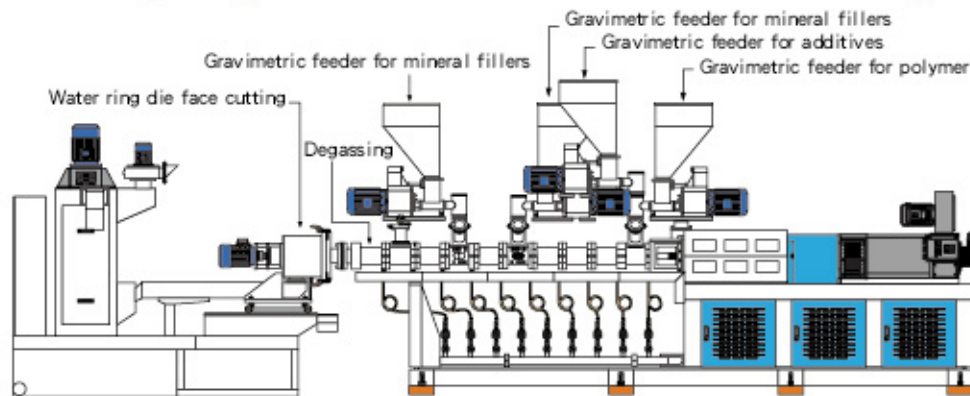

苯乙烯TPE共聚或動態加硫

SBS-SEBS-TPV

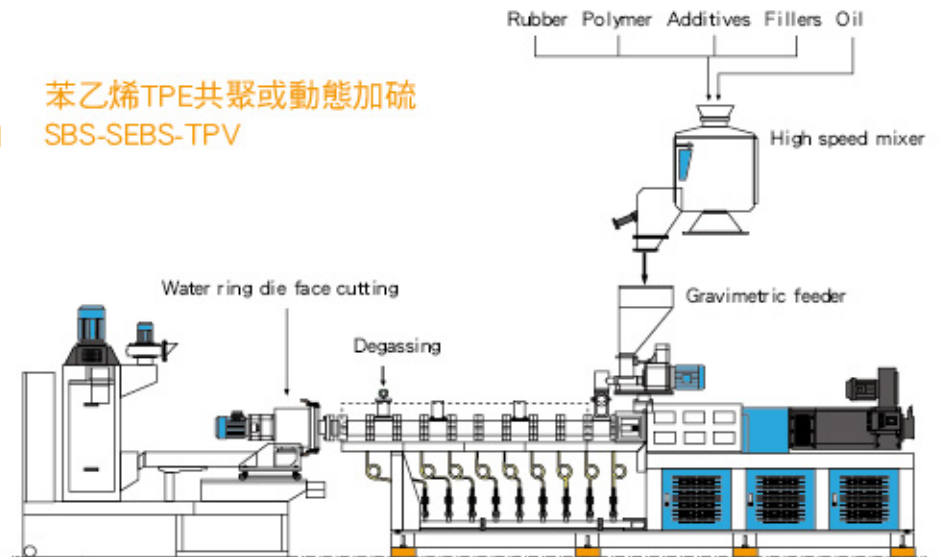

預混色母製程

Premixed color master batch process

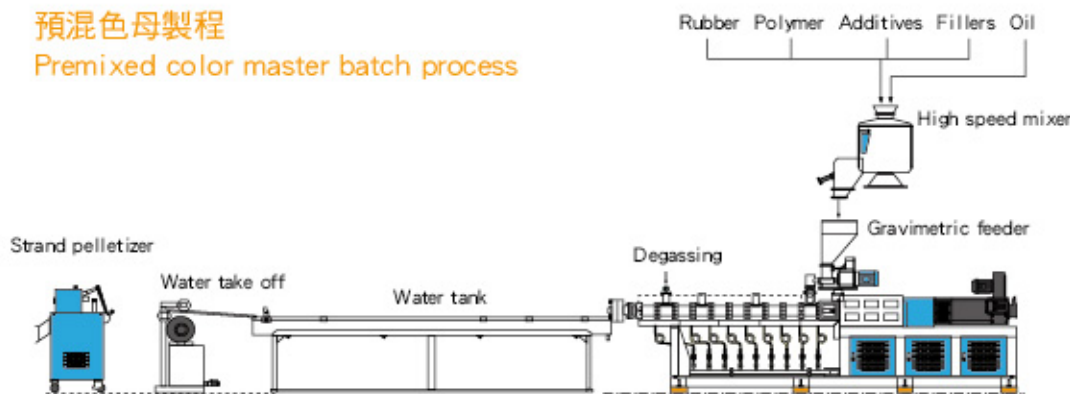

彈性體反應聚合

TPE-Reactive Extrusion

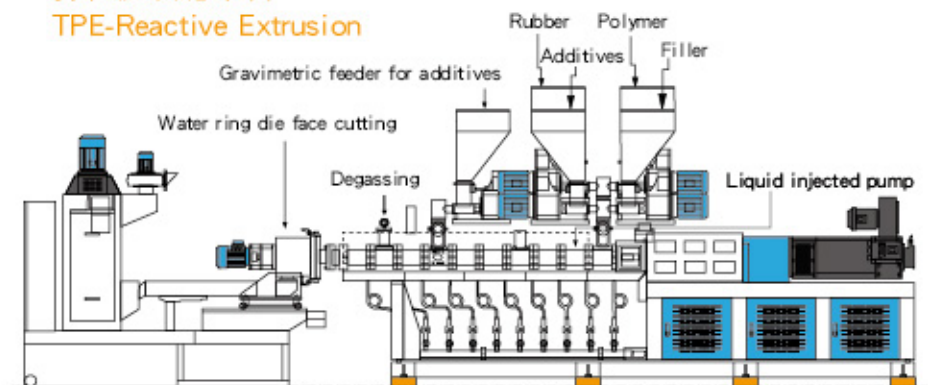

REX系列積木式同向雙螺桿押出機

REX series segmented co-rotating twin screw extruder

流程圖

Flowing chat

色母自動計量分開入料製程

Color Master batch separate feed automatic measuring process

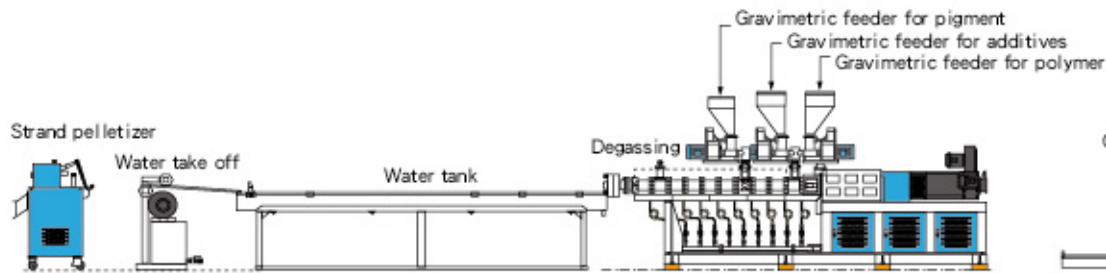

板材單層或多層共擠

Single or multi-layer sheet extrusion line

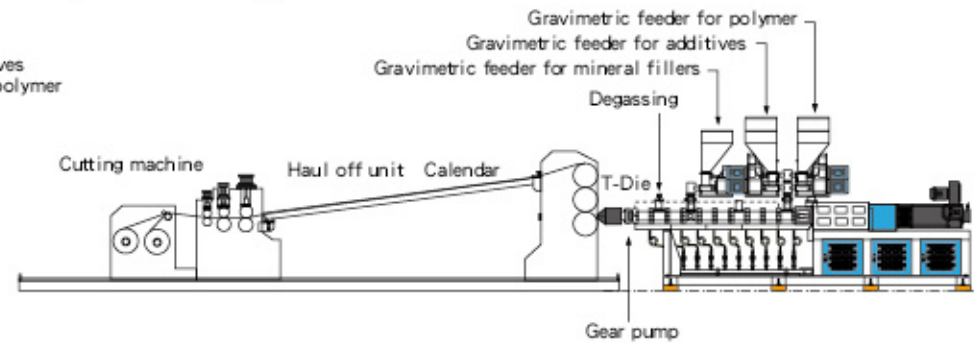

玻纖及礦粉強化

Glass fiber and mineral fillers reinforced compound

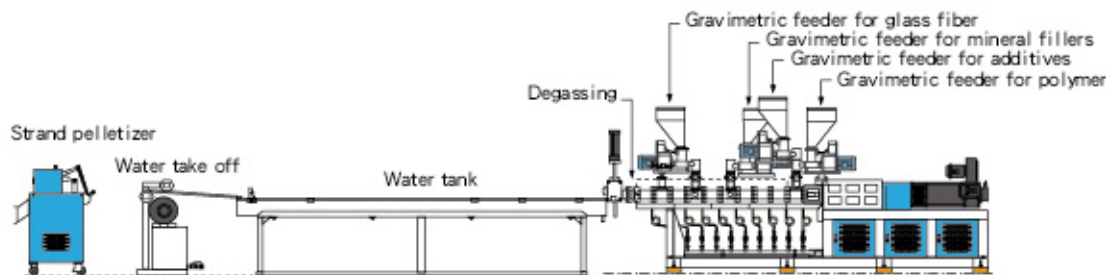

異型材

Profile extrusion line

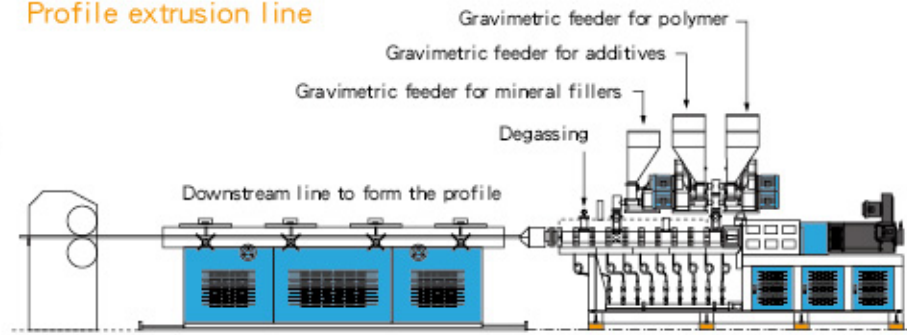



雙段型子母車塑料回收再生造粒機

Two section type waste material recycling extruder



型式(Model No.): SY-HPD-85、100、120、150
Screw diameter: 85 mm、100 mm、120 mm、150mm

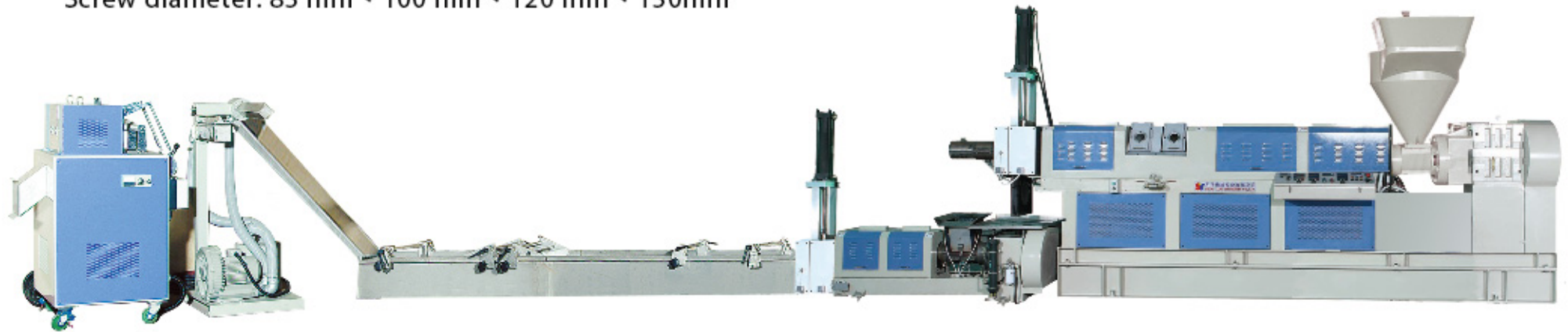

Two section type waste material recycling extruder

1. 使用高效率AC馬達 + 變頻器。
2. 齒輪箱：採用本公司自己設計之高精密度、高轉速、高扭力齒輪箱。
採用強制潤滑冷卻方式來潤滑冷卻齒輪及軸承。在高速運轉時平穩不震動，而且無噪音，齒輪及軸承壽命更長。
3. 螺桿依不同之塑料做不同之設計，且經過特殊表面處理，壽命長、效率高。
4. 料管之設計採用真空脫氣或透氣孔裝置。
5. 料管冷卻方式：風冷或水冷卻
6. 薄膜或薄片採用強制入料漏斗且使用AC變頻馬達。塊狀採用一般漏斗。
7. 適用各種塑料再生造粒(Applications)：
 - A. 薄膜或薄片(Film or flake)：PP、HDPE、LLDPE、LDPE、BOPP、CPP、PET
 - B. 塊狀(Scrap)：ABS、PS、HIPS、PP、PE、PA+GF

Features:

1. Adapt high efficiency AC motor + inverter.
2. Gear Box: using our own design of high precision, high speed, and high torque gear box. Gear Box adapts cooling method of enforced lubrication to cool gear and bearing lubrication. Smooth running at high speed without vibration, and no noise, longer gear and bearing life.
3. Screw design according to different material, and a special treatment, long life and high efficiency.
4. Barrel design uses a vacuum degassing unit.
5. Cooling method: air-cooled or water-cooled
6. Film or flake use enforced feed hopper and adapt AC motor + Inverter. Scrap using the general hopper.

三機一體薄膜回收押出機

Film recycling extruder with agglomerated tank

雙段型拉條造粒 Two section type strand pelletizer

型式(Model No.): SY-HPF-65、85、100、120、150、180

Screw diameter: 65 mm、85 mm、100 mm、120 mm、150 mm、180mm

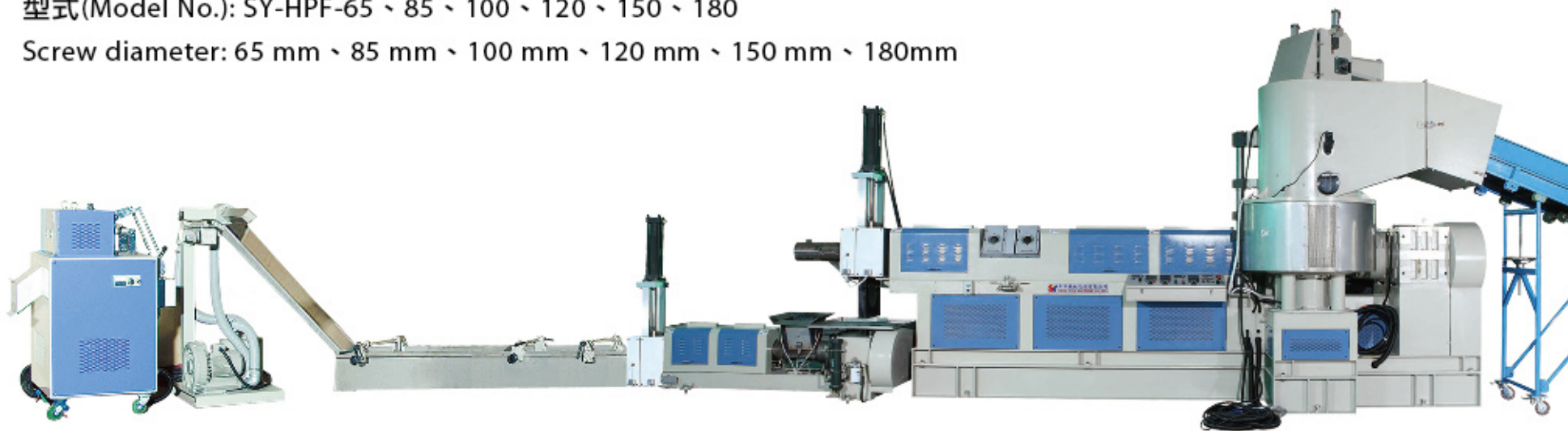

1. 使用DC馬達或高效率AC馬達 + 變頻器。
2. 齒輪箱：採用本公司自己設計之高精密度、高轉速、高扭力齒輪箱。
採用強制潤滑冷卻方式來潤滑冷卻齒輪及軸承。在高速運轉時平穩不震動，而且無噪音，齒輪及軸承壽命更長。
3. 螺桿依不同之塑料做不同之設計，且經過特殊表面處理，壽命長、效率高。
4. 料管之設計採用真空脫氣或透氣孔裝置。
5. 料管冷卻方式：風冷卻
6. 拉條造粒適用廢棄物及不乾淨薄膜回收料。
7. 適用原料 (Applications)：
Waste film of PP、HDPE、LLDPE、LDPE、Agriculture film、
Green house film、PP woven bag、PA yarn、PP yarn、PA net、
PP net、PP non-woven.

Features:

1. Material conveying, crushing, pelletizing are processed in one time.
It can save the cost of labor.
2. Agglomerated tank (shred drum) equip with knife inside and cooling system.
It also has the function of moving the moisture out.
3. Agglomerated tank also equip with haul off unit.
4. The output is higher than standard two section recycling extruder.
5. Adapt DC motor high efficiency AC motor + inverter.



180mm三機一體薄膜回收押出機

Film recycling extruder with agglomerated tank

模頭風冷切粒 Die face air cooling pelletizer

型式(Model No.): SY-HPF-65、85、100、
120、150、180
Screw diameter: 65 mm、85 mm、100 mm、
120 mm、150 mm、180mm



1. 使用DC馬達或高效率AC馬達 + 變頻器。
2. 齒輪箱：採用本公司自己設計之高精密度、高轉速、高扭力齒輪箱。
採用強制潤滑冷卻方式來潤滑冷卻齒輪及軸承。在高速運轉時平穩不震動，而且無噪音，齒輪及軸承壽命更長。
3. 螺桿依不同之塑料做不同之設計，且經過特殊表面處理，壽命長、效率高。
4. 料管之設計採用真空脫氣或透氣孔裝置。
5. 料管冷卻方式：風冷卻
6. 模頭水環切粒適用廠內乾淨薄膜回收料。



7. 適用原料(Applications) :

Film of PP、HDPE、LLDPE、LDPE、PA、
 PET、PA yarn、PP yarn、PA net、PP net、PP non-woven、
 HDPE + 80% CAC03

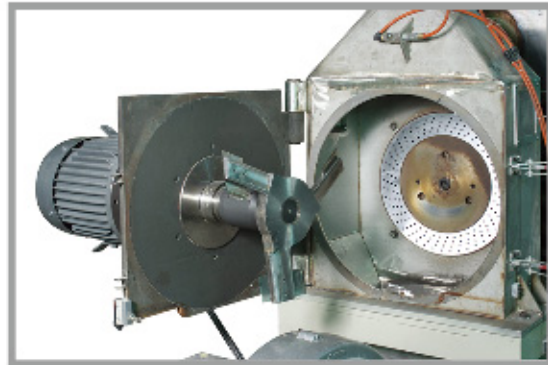

模頭風冷切粒

Die face air cooling palletizer

Feature:

1. Material conveying, crushing, pelletizing are processed in one time.
It can save the cost of labor.
2. Agglomerated tank (shred drum) equip with knife inside and cooling system.
It also has the function of moving the moisture out.
3. Agglomerated tank also equip with haul off unit.
4. The output is higher then standard two section recycling extruder.
5. Adapt DC motor or high efficiency AC motor + inverter.
6. 180mm processing:
 Crushing - buffer tank (temporary tank) - Agglomerated tank-
 Extruder - Die face water ring pelletizing system - Pellets
 Vibrated strainer

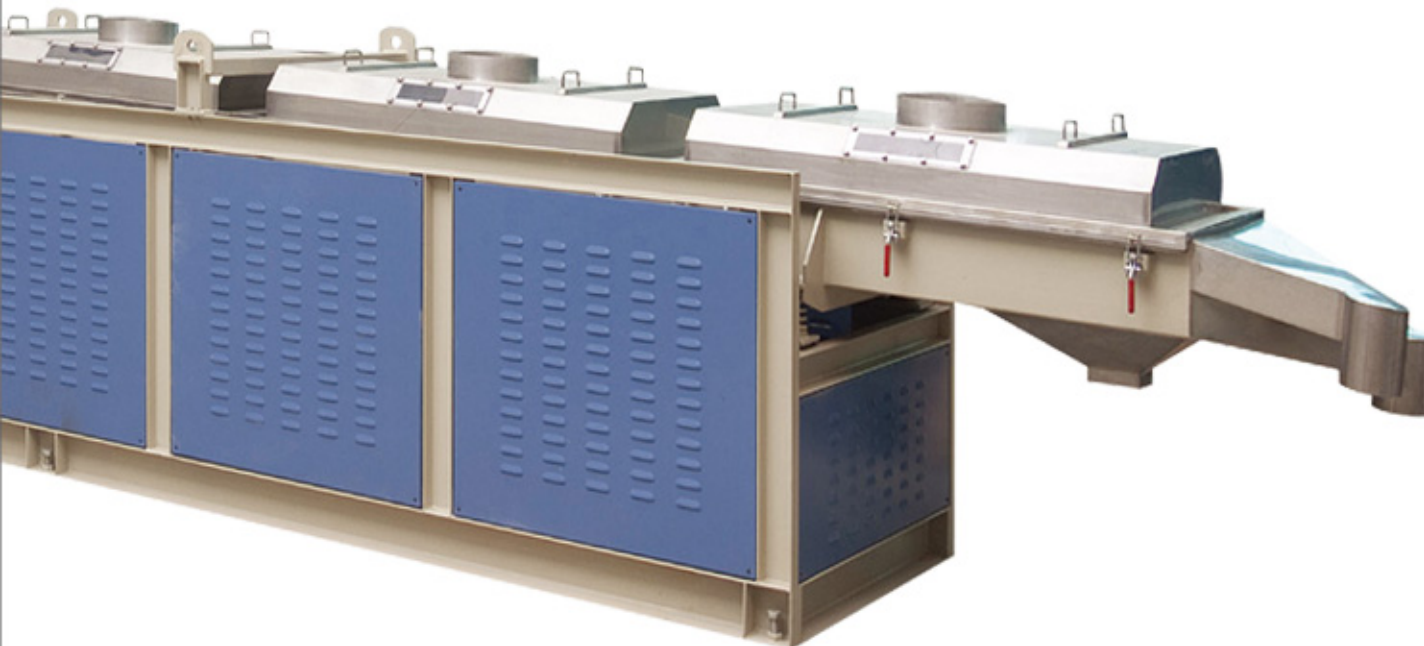

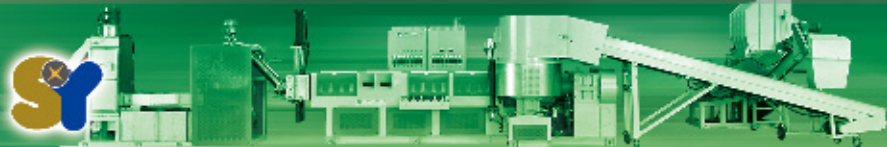

三機一體 薄膜回收押出機

Film recycling extruder with agglomerated tank

YouTube
Broadcast Yourself™



模頭水環切粒 Die face water ring pelletizer PP專用

型式(Model No.):SY-HPF-65、85、100、120、150、180

Screw diameter: 65 mm、85 mm、100 mm、120 mm、150 mm、180mm



1. 使用DC馬達或高效率AC馬達 + 變頻器。
2. 齒輪箱：採用本公司自己設計之高精密度、高轉速、高扭力齒輪箱。
採用強制潤滑冷卻方式來潤滑冷卻齒輪及軸承。在高速運轉時平穩不震動，而且無噪音，齒輪及軸承壽命更長。
3. 螺桿依不同之塑料做不同之設計，且經過特殊表面處理，壽命長、效率高。
4. 料管之設計採用真空脫氣或透氣孔裝置。
5. 料管冷卻方式：風冷卻
6. 模頭水環切粒適用廠內乾淨薄膜回收料。
7. 適用原料(Applications)：Film of PP、HDPE、LLDPE、LDPE (Available factory's clean recycling material.)



三機一體 薄膜回收押出機

Film recycling extruder with agglomerated tank

YouTube
Product Tour



模頭水環切粒

Die face water ring pelletizer

型式(Model No.):

SY-HPF-65、85、100、

120、150、180

Screw diameter:

65 mm、85 mm、

100 mm、120 mm、

150 mm、180mm



Feature:

1. Material conveying, crushing, pelletizing are processed in one time. It can save the cost of labor.
2. Agglomerated tank (shred drum) equip with knife inside and cooling system. It also has the function of moving the moisture out.
3. Agglomerated tank also equip with haul off unit.
4. The output is higher than standard two section recycling extruder.
5. Adapt DC motor or high efficiency AC motor + inverter.

HSF系列 粉碎片及薄膜回收造粒機

Scrap & film recycling extruder

型式(Model No.): SY- HSF65 85 100 120 150
 Screw Diameter: 65mm 85mm 100mm 120mm 150mm

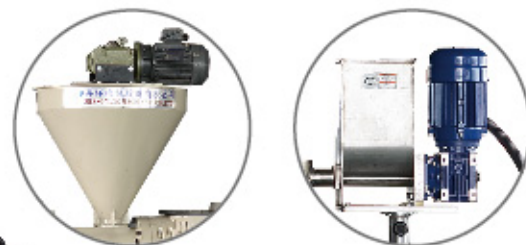
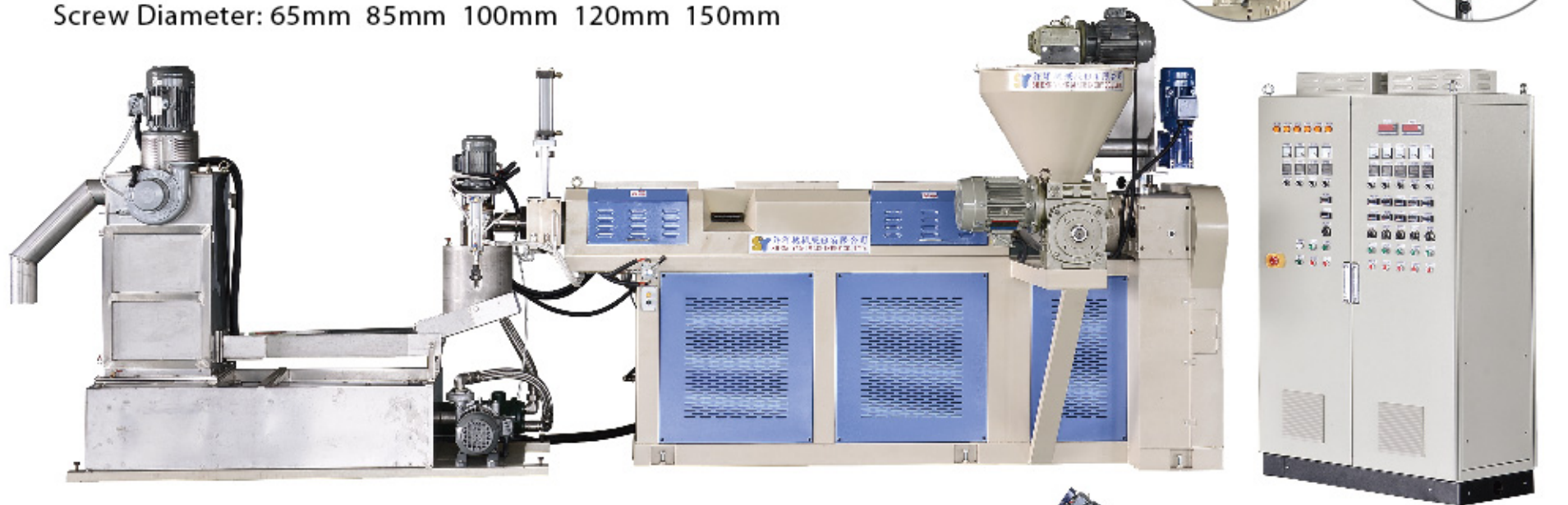

特性：

1. 65mm 回收押出機適用於工廠內部廢料回收。
2. 65mm特別適用於吹袋廠之不良品及模頭料回收。
3. 使用模頭切粒方式，PP、PE 皆可造粒。
4. 薄膜使用強制漏斗，粉碎片使用一般漏斗。
5. 採用一般自然透氣方式，亦可加裝真空脫氣。
6. 本機可回收乾的或濕的薄膜粉碎片。
7. 一機回收粉碎片及薄膜，可節省佔地空間。

Applications / 適用原料：

Scrap / 粉碎片：PP、HDPE、LLDPE、LDPE
 Film / 薄膜：PP、HDPE、LLDPE、LDPE



Features:

1. Screw diameter 65mm is available for inside factory's waste material recycling.
2. Specially use for blowing film manufacturer to recycle their defect and waste material.
3. Cutting method by means of die face water ring pelletizer(Both PP & PE)
4. Equip with forced feeder for film and hopper for scrap.
5. Adapt degassing vent, but it can be installed vacuum degassing vent according.
6. Wet or dry material can be recycled through this extruder.
7. Scrap & film materials recycle from this extruder can save space occupied.

高產能染色、複合材料及回收造粒機

High output coloring, compounding & recycling extruder

型式(Model No.): SY-HPA65、85、100、120、150

Screw diameter: 65 mm、85 mm、100 mm、120 mm、150mm

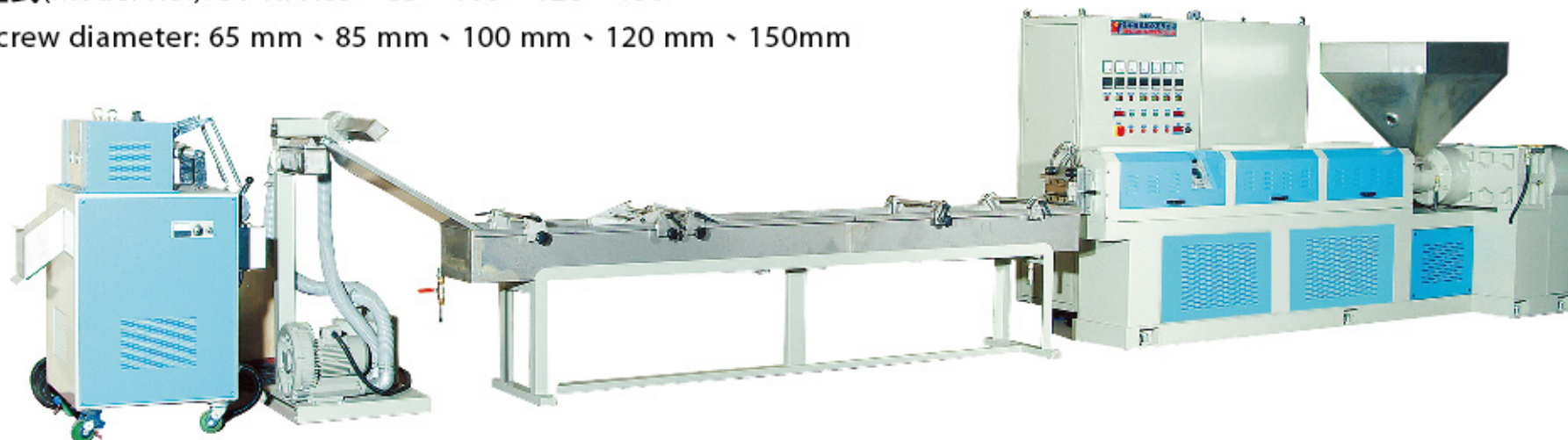

1. 可使用DC馬達或高效率AC馬達 + 變頻器。
2. 齒輪箱：採用本公司自己設計之高精密度、高轉速、高扭力齒輪箱。
採用強制潤滑冷卻方式來潤滑冷卻齒輪及軸承。在高速運轉時平穩不震動，而且無噪音，齒輪及軸承壽命更長。
3. 螺桿依不同之塑料做不同之設計，且經過特殊表面處理，壽命長、效率高。
4. 料管之設計採用真空脫氣裝置。
5. 料管冷卻方式：風冷或水冷卻
6. 適用各種塑料之染色、複合材料及乾淨塑料之再生造粒。
7. 可使用之塑料(Applications)：
PP、PE、PS、PC、PET、PBT、POM、PMMA、PA、
PPE(PPO)、ABS、AS、PC/ABS、TPR、TPE
PP、PA、PC、PBT、ABS + GF
PP + CaCO₃、PP + TALC、PP + TiO₂

Features:

1. Can use the DC motor or high efficiency AC motor + inverter.
2. Gear Box: using our own design of high precision, high speed, and high torque gear box. Gear Box adapts cooling method of enforced lubrication to cool gear and bearing lubrication. Smooth running at high speed without vibration, and no noise, longer gear and bearing life.
3. Screw design according to different material, and a special treatment, long life and high efficiency.
4. Barrel design uses a vacuum degassing unit.
5. Cooling method: air-cooled or water-cooled
6. For the coloring compound, composite materials and clean the recycled plastic granules.



異形材及板材押出機

Profile & Sheet extruder

異形材 Profile:

型式(Model No.): SY-PFP-45、55、65、75、85、100、120

Screw diameter: 45mm、55mm、65mm、75mm、85mm、100mm、120mm

適用原料(Applications): PP、PE、PS、ABS、PC、PVC



板材 Sheet:

型式(Model No.): SY-PFS-45、55、65、85、100、120、150、180

Screw diameter: 45mm、55mm、65mm、85mm、100mm、120mm、
150mm、180mm

適用原料(Applications): PP、PE、PS、PMMA、PC、ABS

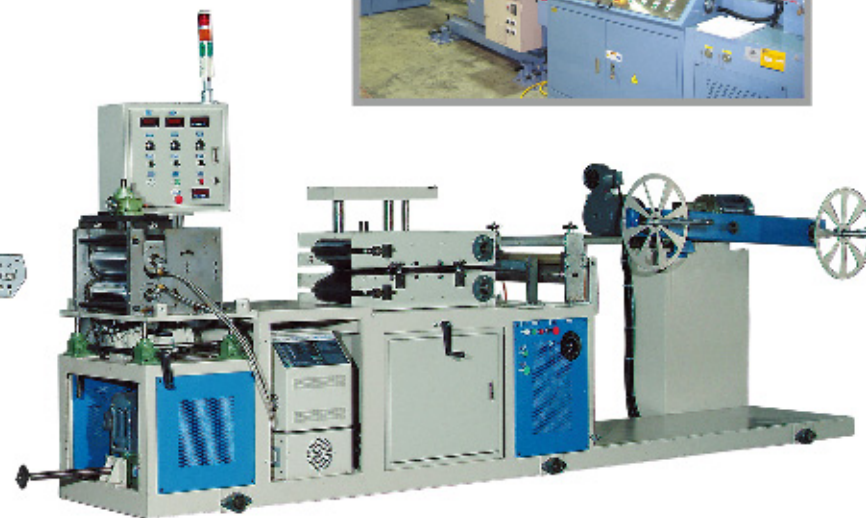
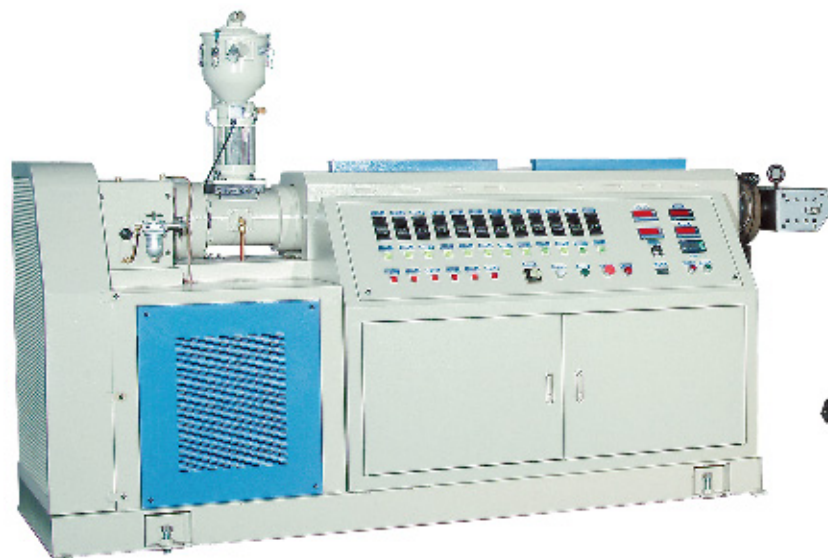

塑膠廢料 回收清洗整廠設備

Waste plastic recycling turn key equipment



● 雙軸破碎機 Twin shaft shredder



● 強力粉碎機 Powerful crusher



● 清洗設備 Washing system



● 裁斷機 crusher

整廠製程 (Turn key processing line) :

1. 雙軸破碎機 Twin shaft shredder
2. 強力粉碎機 Powerful crusher
3. 清洗設備 Washing system
4. 薄膜擠乾機 Film squeezed Machines
5. 回收造粒押出機 Recycling pelletizing extruder

適用原料 (Applications) :

1. PET bottle
2. HDPE : Chemical tank, Oil tank, Shower cream container, Milk container
Yogurt container
3. LDPE: Facial Foam container, Facial cosmetics container
4. PP、PE film : Agriculture film, Green house film, Shopping bag, Package film.

周邊配備

Downstream equipment

Downstream equipment



● 高速混合機 High-speed Mixer



● 切粒機 Granulator



● 比例式進料機 Feeder

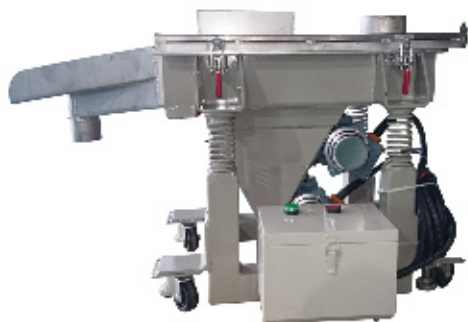

● 迷你型震動選料機 Pellets Vibrated Strainer



● 震動選料機 Pellets Vibrated Strainer

周邊配備

Downstream equipment



● 立式混合機 Vertical Mixer



● 立式混合乾燥機 Vertical Drying Mixer



● 臥式乾燥混合機 Horizontal Drying Mixer



● 臥式攪拌機 Horizontal Mixer

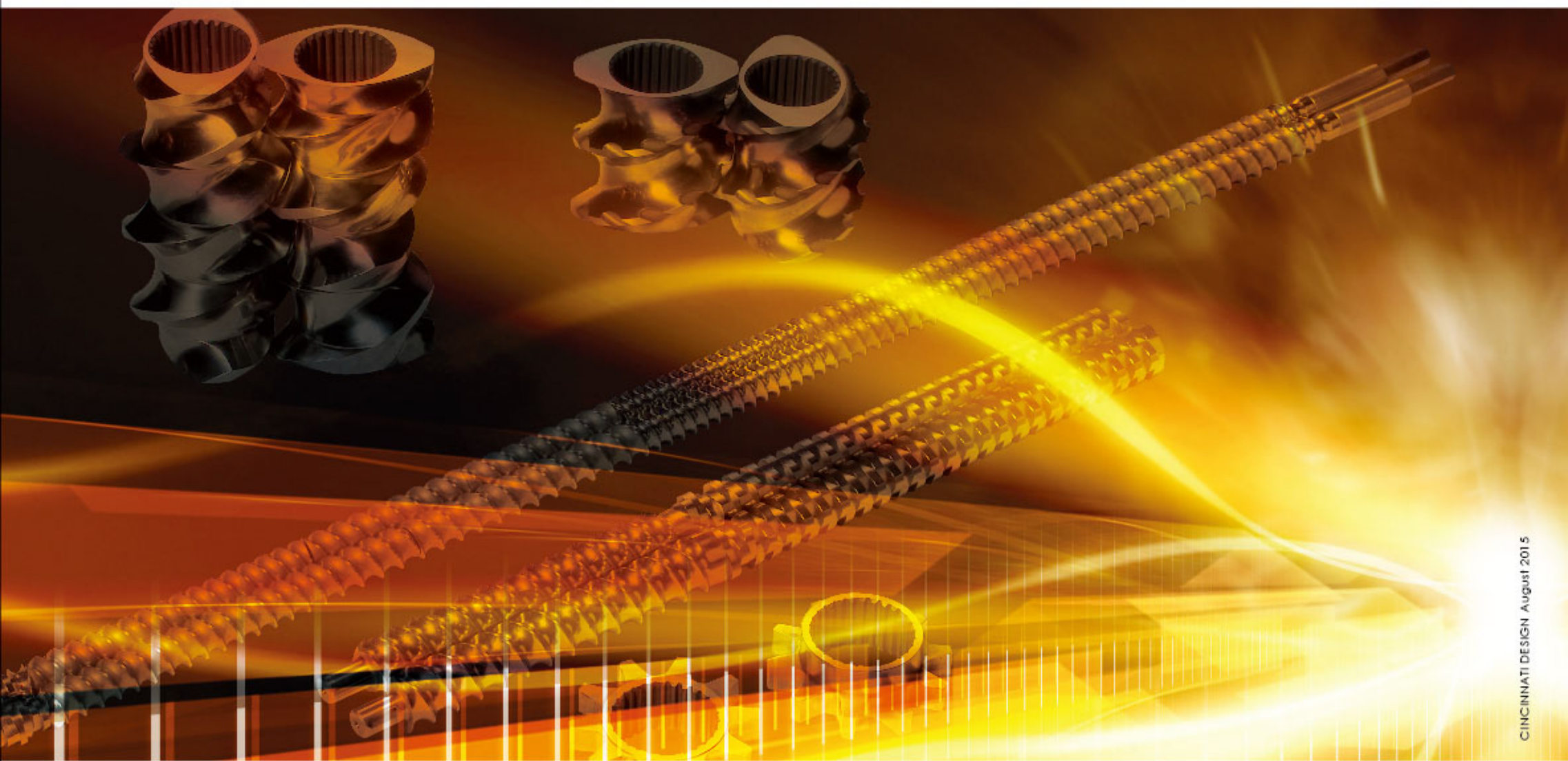

CINCINNATI DESIGN AUGUST 2015



昇洋機械股份有限公司
SHENG YANG MACHINERY CO., LTD.

71066 台南市永康區正南五街65號
No.65, Jhongjheng 5th St., Yongkang Dist.,
Tainan City 71066, Taiwan (R.O.C.)

Tel:+886-6-2533055 Fax:+886-6-2533505
<http://www.symc.com.tw>
E-mail:plas.tech@msa.hinet.net